

320R-RAC Series

Gasoline Fuel Filter/Water Separators

Instruction Part Number 22237 Rev. E



320R-RAC series filters are designed for high-performance applications, which means your engine will perform better than ever with clean, water-free fuel.

Features and benefits include:

- The 320R-RAC-02 is UL Listed and USCG approved for inboard marine use
- Includes high-capacity 10 micron Aquabloc® media
- Has a 60 GPH (227 LPH) maximum flow rate
- Has superior corrosion resistance with a electrostatic powder paint coating
- Includes a 3-port die-cast aluminum mounting head with 1/4"-18 NPTF threads
- Removes 99% of free water



Contact Information

Parker Hannifin Corporation
Racor Division
 P.O. Box 3208
 3400 Finch Road
 Modesto, CA 95353

Phone 800 344 3286
 209 521 7860
Fax 209 529 3278
Email racor@parker.com
Web parker.com/racor



Specifications	320R-RAC-01	320R-RAC-02
Application: Inboard Outboard	No Yes	Yes Yes
Maximum Flow Rate	60 GPH (227 LPH)	60 GPH (227 LPH)
Center Threads	1"-14	1"-14
Port Size	1/4"-18 NPTF	1/4"-18 NPTF
Number of Ports: Inlets Outlets	2 1	2 1
Height	9.3 in. (23.6 cm)	9.0 in. (22.8 cm)
Width	4.0 in. (10.2 cm)	4.0 in. (10.2 cm)
Depth	4.0 in. (10.2cm)	4.0 in. (10.2cm)
Weight (dry)	2.0 lb (0.90 kg)	2.0 lb (0.90 kg)
Clean Pressure Drop	0.61 PSI (4.23 kPa)	0.61 PSI (4.23 kPa)
Maximum Pressure	7 PSI (0.5 bar)	7 PSI (0.5 bar)
Underbowl Clearance	1.0 in. (2.5 cm)	1.0 in. (2.5 cm)
Water Removal Efficiency	99%	99%
Ambient Temperature Range	-40° to +255°F (-40° to +124°C)	
Maximum Fuel Temperature	190°F (32°C)	

Installation Guidelines

Danger! Great care must be exercised to avoid potential fire hazards during installations on gasoline fuel systems. Do not smoke or permit open flames or sparks near the fuel system.

Refer to Installation Diagram on page 4 prior to beginning installation.

1. Any secondary or pressure side filters located between pump and engine should be serviced and left in place.
2. Mount unit vertically on suction side of fuel pump, transfer pump, or non-removable filters, whichever comes first.
3. Ensure a suitable pipe thread sealing compound is used on NPT threads of fitting prior to installation into head. For mounting flexibility, there are two inlet ports and one outlet port. Plated steel fittings are recommended. Plug unused port with provided steel NPT plug—do not use tapes on NPT threads.
4. Use quality fuel hose in maximum fuel line size applicable to reduce potential fuel flow restrictions. Note: USCG accepted hose recommended.

Priming

1. Carefully spin off filter with bowl, then fill with clean fuel (use a strap wrench near top of spin-on filter to remove it).
2. Spin filter with bowl onto mounting head and tighten snugly by hand—do not use tools to tighten.
3. Start engine and check for leaks. If engine is difficult to start or runs rough, check that drain, bowl, filter, and port plug are securely tightened. Check all connections for security and hoses to ensure there are no kinks or sharp bends that would create excessive restriction.

Service

Danger! When servicing gasoline fuel systems, extreme care must be exercised to avoid potential fire hazards. Do not smoke or permit open flames near fuel during servicing procedures.

Draining The Bowl

Water is heavier than fuel and will settle at bottom of bowl and appear different in color. In extremely humid conditions, take a fuel sample (in clear container) frequently, and drain as required if water is present.

1. Place a suitable container below unit to collect contaminants.
2. Close fuel tank valve, if applicable, then open self-venting drain (-01 model) or loosen/remove drain plug (-02 model) at bottom of bowl. Note: a UL Listed drain valve kit is available for -02 models, order part no. RK 19492.
3. Prime fuel system following the manufacturer's procedure - refer to Priming.

Filter Replacement

Filter replacement frequency is determined by contamination levels in fuels. Fuel flow to engine becomes restricted as filter slowly plugs with contaminants, resulting in noticeable power loss and/or hard starting. Replace filter annually, every 500 hours, or when there is a noticeable power loss, whichever comes first. Change filter as soon as possible. **Note: always carry extra replacement filters as one tankful of excessively contaminated fuel can plug a filter.**

Clean any debris or dirt away from Racor head/filter joint prior to removal.

1. Place a suitable container below unit to collect contaminants.
2. Close valve at fuel tank, if applicable, open or remove drain (plug) to empty filter of fuel.
3. Spin filter and bowl off together (use a strap wrench on filter), then remove bowl from filter.
4. Clean, bowl O-ring gland and sealing surface of mounting head, of dirt, debris, or gums.
5. Apply lube oil to new seal and bowl O-ring supplied with new filter.
6. Place new seal onto top of new filter and O-ring into bowl gland.
7. Spin bowl onto filter, then both onto head. Tighten snugly by hand - do not use tools to tighten.
8. Prime fuel system following manufacturer's procedure - refer to Priming.

320R-RAC-01 Replacement Parts

<u>Part No.</u>	<u>Description</u>
1. RK 20180	Mounting Head Kit
2. RK20505-01	Gasket Kit
3. S3227	10 Micron Replacement Filter
4. RK33544	Bowl O-ring Kit
5. RK33546	Clear Bowl Kit
6. RK 30476	Self-venting Drain Kit

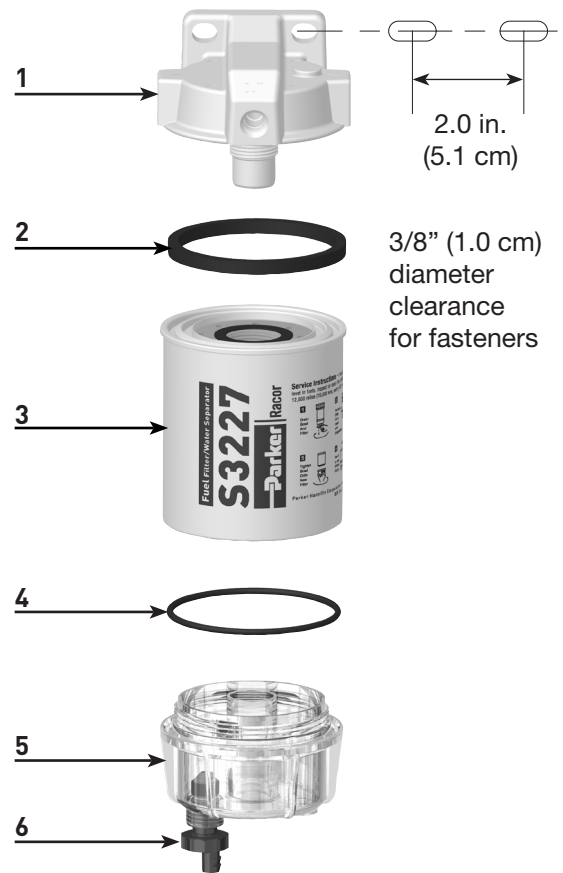

320R-RAC-02 Replacement Parts

<u>Part No.</u>	<u>Description</u>
1. RK 20180	Mounting Head Kit
2. RK20505-01	Gasket Kit
7. S3228TUL	10 Micron Replacement Filter
8. RK33544	Bowl O-ring Kit
9. RK 30473-02	Metal Bowl Kit
10. 918-N6	Steel Port Plug

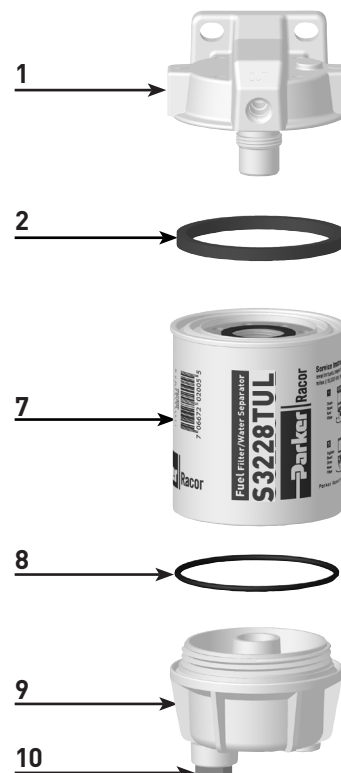

Drain Valve Kit

*UL Listed drain valve kit is available for
-02 models. Part number RK 19492.*



Installation Diagram

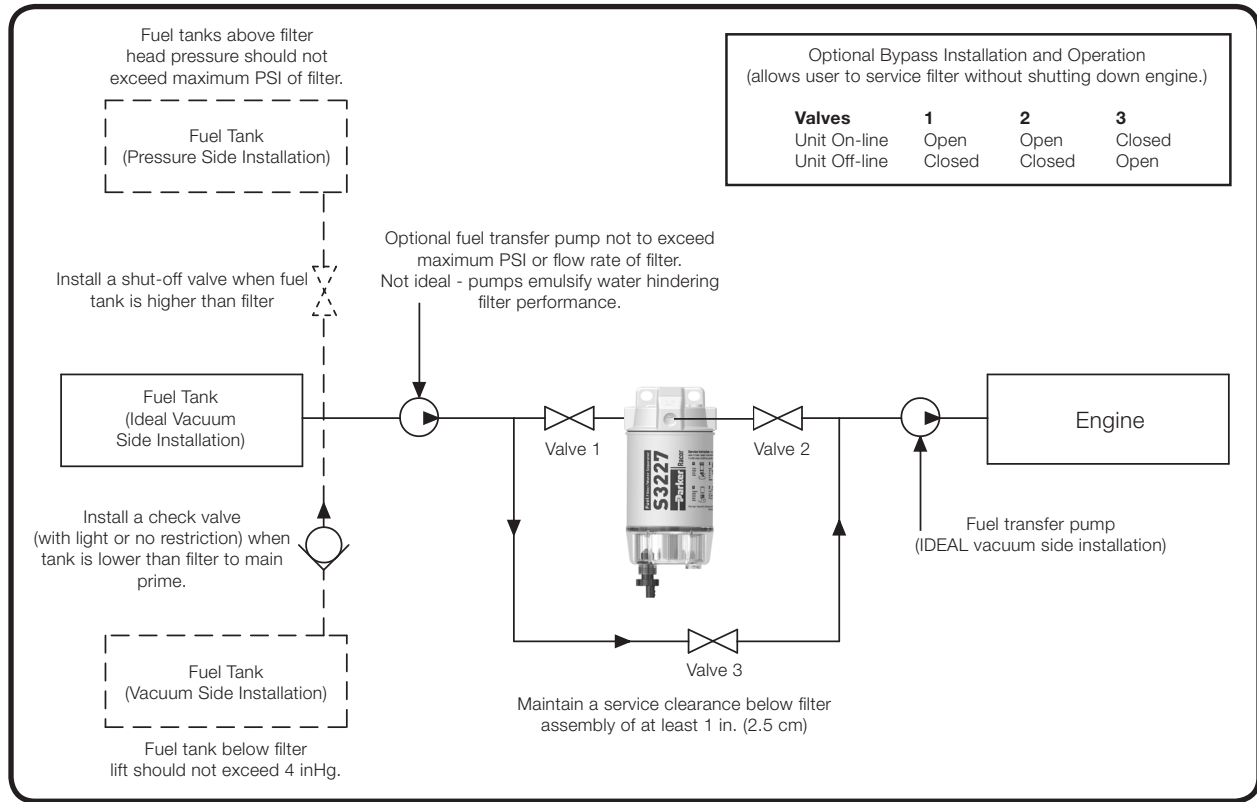

Limited Warranties Statement

All products manufactured or distributed by Racor are subject to the following, and only the following, LIMITED EXPRESS WARRANTIES, and no others: For a period of one (1) year from and after the date of purchase of a new Racor product, Racor warrants and guarantees only to the original purchaser-user that such a product shall be free from defects of materials and workmanship in the manufacturing process. The warranty period for pumps and motors is specifically limited to ninety (90) days from date of purchase. A product claimed to be defective must be returned to the place of purchase. Racor, at its sole option, shall replace the defective product with a comparable new product or repair the defective product. This express warranty shall be inapplicable to any product not properly installed and properly used by the purchaser-user or to any product damaged or impaired by external forces.

THIS IS THE EXTENT OF WARRANTIES AVAILABLE ON THIS PRODUCT. RACOR SHALL HAVE NO LIABILITY WHATSOEVER FOR CONSEQUENTIAL DAMAGES FLOWING FROM THE USE OF ANY

DEFECTIVE PRODUCT OR BY REASON OF THE FAILURE OF ANY PRODUCT. RACOR SPECIFICALLY DISAVOWS ALL OTHER WARRANTIES, EXPRESS OR IMPLIED INCLUDING, WITHOUT LIMITATION, ALL WARRANTIES OF FITNESS FOR A PARTICULAR PURPOSE (EXCEPT FOR THOSE WHICH APPLY TO PRODUCT OR PART THEREOF THAT IS USED OR BOUGHT FOR USE PRIMARILY FOR PERSONAL, FAMILY, OR HOUSEHOLD PURPOSES), WARRANTIES OF DESCRIPTION, WARRANTIES OF MERCHANTABILITY, TRADE USAGE OR WARRANTIES OR TRADE USAGE.

Warning

Failure or improper selection or improper use of the products and/or systems described herein or related items can cause death, personal injury and property damage. This document and other information from Parker Hannifin Corporation, its subsidiaries and authorized distributors provide product and/or system options for further investigation by users

having technical expertise. It is important that you analyze all aspects of your application and review the information concerning the product or system in the current product catalog. Due to the variety of operating conditions and applications for these products or systems, the user, through its own analysis and testing, is solely responsible for making the final selection of the products and systems and assuring that all performance, safety and warning requirements of the applications are met.

The products described herein, including with limitation, product features, specifications, designs, availability and pricing, are subject to change by Parker Hannifin Corporation and its subsidiaries at any time without notice.

The following statement is required pursuant to proposition 65, applicable in the State of California: 'This product may contain a chemical known to the State of California to cause cancer or reproductive toxicity.'